



NEXT.assembly

# x-cal weight

## Test and calibration device for weighing systems in wheel alignment stand x-wheel

Today, conventional calibration weights no longer meet the modern requirements of a quality-conscious check of the weighing technology at the end of the line. The new test and calibration device x-cal weight with certified measuring chain represents the innovative solution for testing and calibrating the weighing technology of a x-wheel wheel alignment stand integrated in the floating plates. It replaces calibration weights that are difficult to handle.

### PRINCIPLE OF WEIGHING TECHNOLOGY

In case of the wheel alignment test stand each wheel support consists of a pair of rollers and a floating plate. The floating plate rests on four ball bearings. Under the ball bearings the corresponding weighing cells are arranged. They are connected with the test stand control via measurement amplifiers. These weighing cells must be verified and calibrated at regular intervals.

### CUSTOMER BENEFITS



Replacing the difficult to handle calibration weights

Assembly of the device without tools

Faster verification and calibration compared to conventional methods

Automatic generation of a test certificate

# x-cal weight

## Test and calibration device for weighing systems in wheel alignment stand x-wheel

### APPLICATION

- In order to use the calibration system the mechanical components are mounted onto the wheel alignment test stand at the respective floating plate.
- The calibration system generally consists of a loading unit with integrated force transducer and a weighing indicator for displaying the test load. The measuring chain of the calibration system has been certificated.
- By comparing the acting test load with the corresponding measuring value in the wheel alignment test stand the respective measuring amplifier can be adjusted exactly. Only then, a precise determination of the vehicle weight in the wheel alignment test stand is guaranteed.

The following procedures can be carried out „menu-controlled“ by means of the appropriate software:

- Initialize the weighing unit
- Execute the idle test of the weighing system
- Linearity testing of the weighing system
- Set the weighing system to „zero“
- Calibrate the weighing system

### FEATURES

- The nominal test load is 750 kg
- The maximum allowed test load is 1000 kg
- The entire test system will be delivered in a solid aluminium roll box

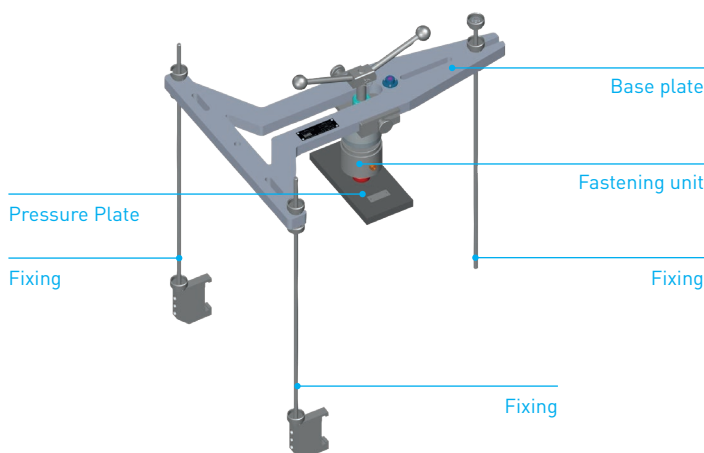

Layout x-cal weight



Test set in aluminium roll box



Weighing indicator



### CONTACT

**Dürr Assembly Products GmbH**  
Köllner Straße 122 - 128  
66346 Püttlingen, Germany  
Telefon: +49 (0)6898 692-0  
E-Mail: [service-dap@durr.com](mailto:service-dap@durr.com)  
[www.durr.com](http://www.durr.com)